

Bottom view / Вид снизу

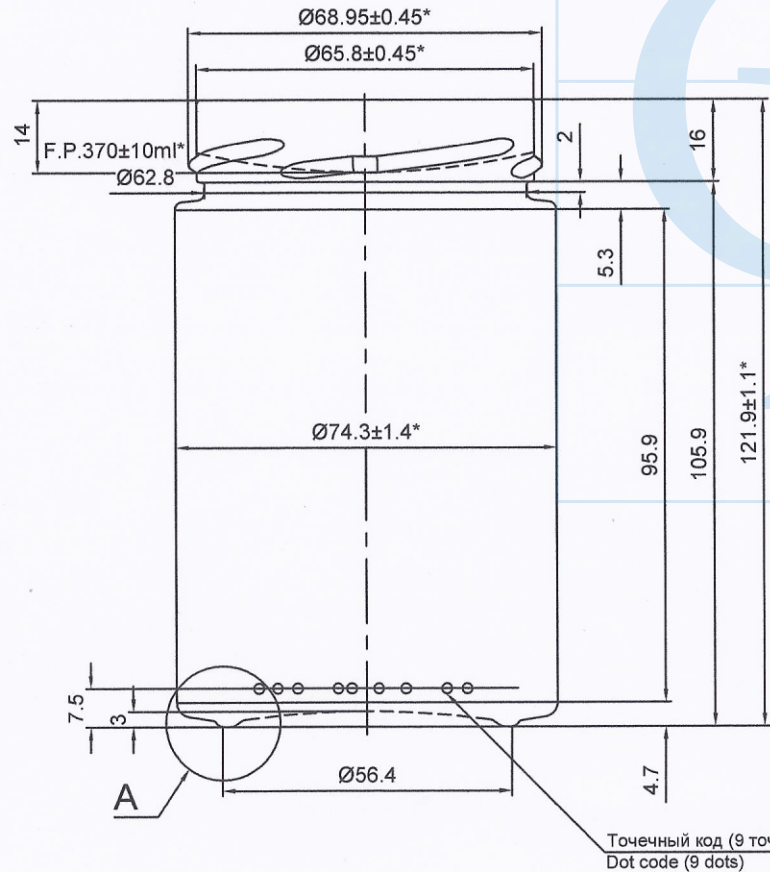

A  
4:1

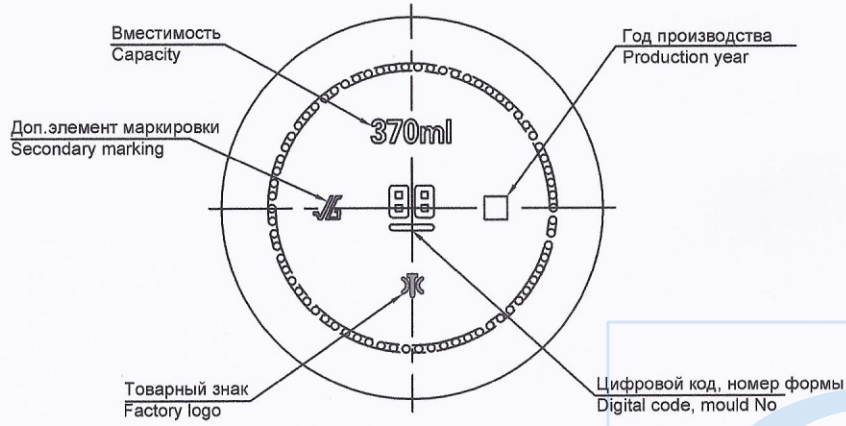
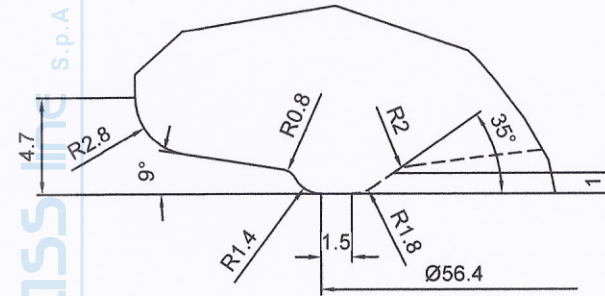

- \*Контролируемые размеры. Остальные размеры для изготовления формокомплекта. (Controlling dimensions. Other dimensions for the manufacture of mold sets.)
- Полная вместимость, см<sup>3</sup> (Full capacity, ml) - 409±10;
- Номинальная вместимость, см<sup>3</sup> (Nominal capacity, ml) - 370±10;
- Масса рекомендуемая, г (Weight recommended, g) - 220;
- Тип венчика (Finish type) -III-4-70(TO-70 DEEP);
- Толщина минимальная (Minimum Thickness):  
 - стенок, мм (Wall, mm) -1,2;  
 - дна, мм (Bottom, mm) -2,0.

7. Технические требования по ГОСТ 5717-91 и по ТУ У 26.1-04763746-027:2009.  
 (Technical requirements according to ГОСТ 5717-91 and ТУ У 26.1-04763746-027:2009)

NAME	DATE	REVISIONS	MOLD No:			A3	CENTERGLASSLINE SPA	
V.Y.	08.12.17	Added logo on the bottom	FINISH No:					
V.Y.	02.02.18	Changed body dimens., brimf.capacity, F.P., height	PROCESS	PB	MACHINE	DG 5 1/2"	JAR:	
			TYPE	OW	TIP ANGLE	-	ELENA 370ML	
			CAP. BRIMF.	409±10ml	REF MOLD:	-	CAT.No & DWG No:	
			CAP. FILLPT.	370±10ml	FINISH:	III-4-70(TO-70 DEEP)	3.92-III-4-70-370	
			FILL LINE	14mm	DRAWN	Yatsentiuk		
			WEIGHT	220g	CHECKED	Dovgopol	DATE	16/11/17
			COLOR	FLINT	CONFIRMED	Solomon	SHEET: 1/1	SCALE: 1:1